



**AVERY  
DENNISON**

Fastener  
Solutions

# **11" Double Headed Cable Ties Marketing Specifications**

For the following part numbers:

10430-0

10431-0

10432-0

August 1, 2018

# AVERY DENNISON MARKETING SPECIFICATION

## HISTORY

THE SUBJECT MATTER DISCLOSED HEREIN EMBODIES PROPRIETARY INFORMATION WHICH IS THE CONFIDENTIAL PROPERTY OF THE AVERY DENNISON CO. NONE OF WHICH SHALL BE COPIED, REPRODUCED, DISCLOSED TO OTHERS, PUBLISHED OR USED IN WHOLE OR IN PART, FOR ANY PURPOSE OTHER THAN THAT FOR WHICH IT IS BEING MADE AVAILABLE WITHOUT THE EXPRESS ADVANCE WRITTEN PERMISSION OF A DULY AUTHORIZED AGENT OF THE COMPANY. THIS DOCUMENT IS THE PROPERTY OF THE AVERY DENNISON CO. AND IS TO BE RETURNED TO THE COMPANY ON DEMAND.

REV.	DATE	DESCRIPTION
L	10.14.14	ADDED MIN INSTALL TEMP; UL LOGO AND 5000 PER CASE CHG LOOP TENSILE TO NEWTONS

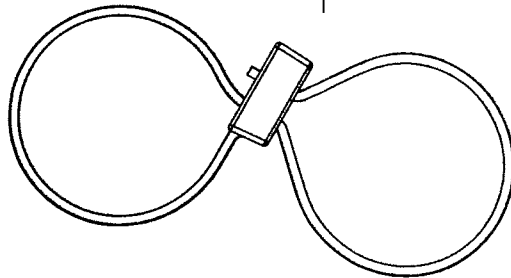
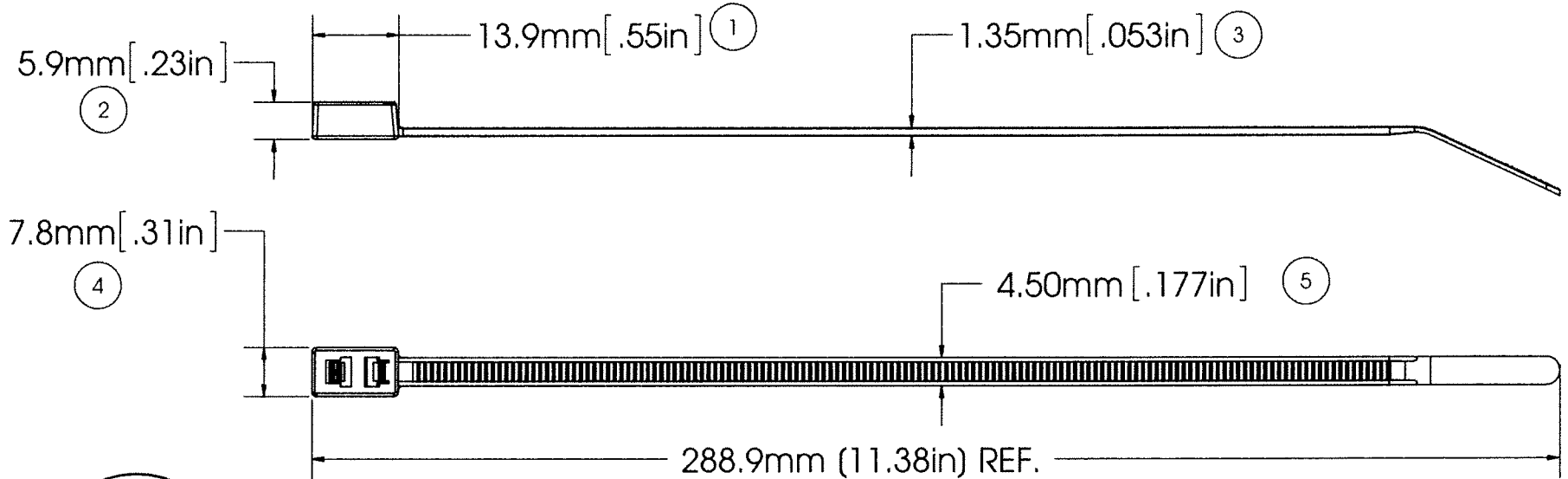

**ASSEMBLED VIEW**



LOOP TENSILE STRENGTH:	50 LBF / 220N MIN. PER AS-23190
OPERATING TEMP RANGE:	-40°F (-40°C) TO 185°F (85°C)
MIN. INSTALLATION TEMP.:	32°F (0°C)
WEIGHT:	0.070 OZ./1.994 GRAMS
BUNDLE DIAMETER:	.063" MIN TO: ONE LOOP UP TO Ø3" OR TWO LOOPS UP TO Ø1.38 EACH
TOOL:	12001 - HAND INSTALLATION TOOL 12500 - PNUEM. INSTALLATION TOOL
TOOL TENSION SETTING:	6 - 8
PACKAGING:	1000/BAG 5000/CASE

NOTE: THESE CABLE TIES ARE PLENUM RATED AND HAVE A FLAMMABILITY RATING OF V-2

APPROVALS: ENG. APPR. *[Signature]* 10/14/14  
Q.A. APPR. *[Signature]* 10/14/14

**AVERY DENNISON**  
FASTENER DIVISION  
FITCHBURG, MA 01420 U.S.A.  
TEL. 1-800-225-9913  
FAX. 978-353-8157

SPECIFIED TOLERANCES ARE:		MATERIAL	DESCRIPTION
.XX ± .03 IN.	.X ± .7 MM	<b>NYLON 6/6</b>	<b>1 1/2" CABLE TIE, STD, DOUBLE HEADED</b>
.XXX ± .01 IN.	.XX ± .25 MM	COLOR	STOCK NO.
ANGULAR: ± 2°		<b>NATURAL</b>	<b>10430-0</b>
			REV. <b>L</b>

# EVERY DENNISON MARKETING SPECIFICATION

## HISTORY

THE SUBJECT MATTER DISCLOSED HEREIN EMBODIES PROPRIETARY INFORMATION WHICH IS THE CONFIDENTIAL PROPERTY OF THE AVERY DENNISON CO. NONE OF WHICH SHALL BE COPIED, REPRODUCED, DISCLOSED TO OTHERS, PUBLISHED OR USED IN WHOLE OR IN PART, FOR ANY PURPOSE OTHER THAN THAT FOR WHICH IT IS BEING MADE AVAILABLE, WITHOUT THE EXPRESS ADVANCE WRITTEN PERMISSION OF A DULY AUTHORIZED AGENT OF THE COMPANY. THIS DOCUMENT IS THE PROPERTY OF THE AVERY DENNISON CO. AND IS TO BE RETURNED TO THE COMPANY ON DEMAND.

REV.	DATE	DESCRIPTION
L	10.02.13	UPDATED TO NEW FORMAT; ADDED TEMP RATING
M	10.14.14	ADDED MIN INSTALL TEMP; UL LOGO AND 5000 PER CASE CHG LOOP TENSILE TO NEWTONS

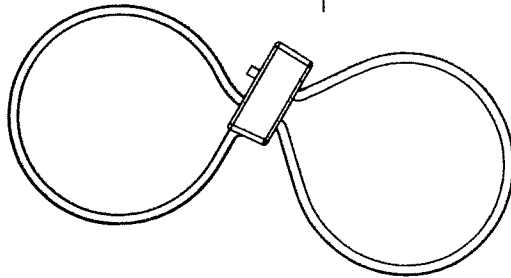
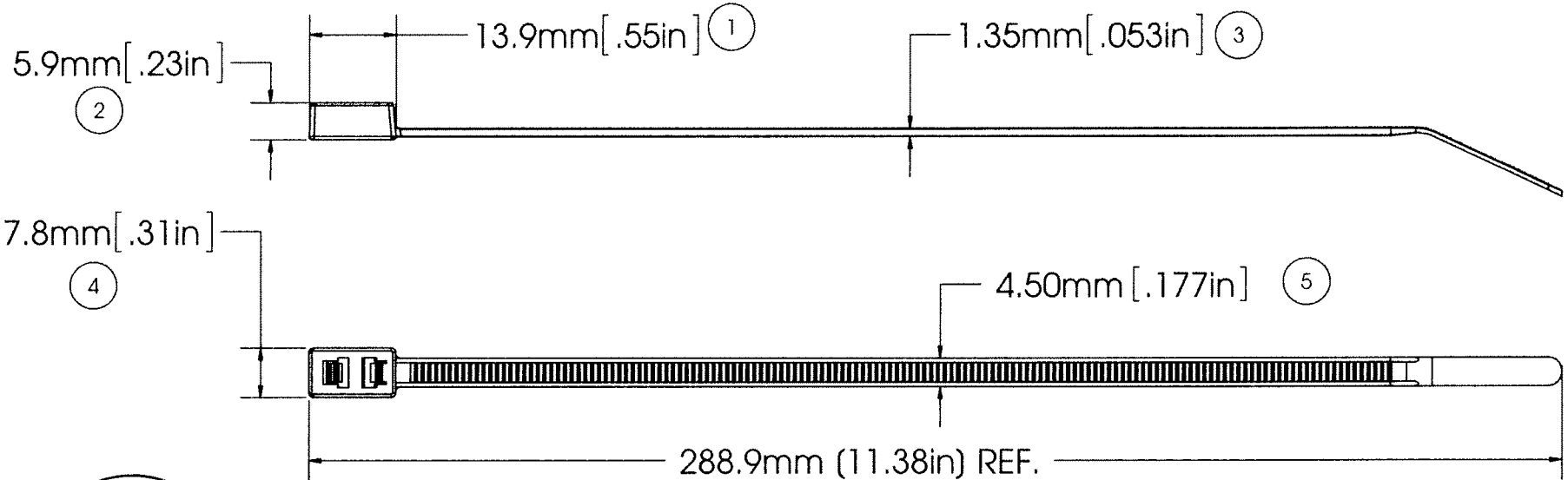

**ASSEMBLED VIEW**



LOOP TENSILE STRENGTH:	50 LBF / 220N MIN. PER AS-23190
OPERATING TEMP RANGE:	-40°F (-40°C) TO 220°F (105°C)
MIN. INSTALLATION TEMP.:	32°F (0°C)
WEIGHT:	0.070 OZ./1.994 GRAMS
BUNDLE DIAMETER:	.063" MIN TO: ONE LOOP UP TO Ø3" OR TWO LOOPS UP TO Ø1.38 EACH
TOOL:	12001 - HAND INSTALLATION TOOL 12500 - PNUEM. INSTALLATION TOOL
TOOL TENSION SETTING:	6 - 8
PACKAGING:	1000/BAG 5000/CASE

NOTE: THESE CABLE TIES ARE PLENUM RATED AND HAVE A FLAMMABILITY RATING OF V-2

APPROVALS: ENG. APPR. *[Signature]* 10/14/14  
Q.A. APPR. *[Signature]* 10/14/14

**AVERY DENNISON**  
FASTENER DIVISION  
FITCHBURG, MA 01420 U.S.A.  
TEL. 1-800-225-5913  
FAX. 978-353-8157

SPECIFIED TOLERANCES ARE:		MATERIAL
.XX ± .03 IN.	.X ± .7 MM	<b>NYLON 6/6, HEAT STABILIZED</b>
.XXX ± .01 IN.	.XX ± .25 MM	COLOR
ANGULAR: ± 2°		<b>BLACK</b>

DESCRIPTION	<b>11" CABLE TIE, STD, DOUBLE HEADED</b>	
STOCK NO.	<b>10431-0</b>	REV. <b>M</b>

# AVERY DENNISON MARKETING SPECIFICATION

## HISTORY

REV.	DATE	DESCRIPTION
L	10.14.14	ADDED MIN INSTALL TEMP; UL LOGO AND 5000 PER CASE CHG LOOP TENSILE TO NEWTONS

THE SUBJECT MATTER DISCLOSED HEREIN EMBODIES PROPRIETARY INFORMATION WHICH IS THE CONFIDENTIAL PROPERTY OF THE AVERY DENNISON CO. NONE OF WHICH SHALL BE COPIED, REPRODUCED, DISCLOSED TO OTHERS, PUBLISHED OR USED IN WHOLE OR IN PART, FOR ANY PURPOSE OTHER THAN THAT FOR WHICH IT IS BEING MADE AVAILABLE WITHOUT THE EXPRESS ADVANCE WRITTEN PERMISSION OF A DULY AUTHORIZED AGENT OF THE COMPANY. THIS DOCUMENT IS THE PROPERTY OF THE AVERY DENNISON CO. AND IS TO BE RETURNED TO THE COMPANY ON DEMAND.

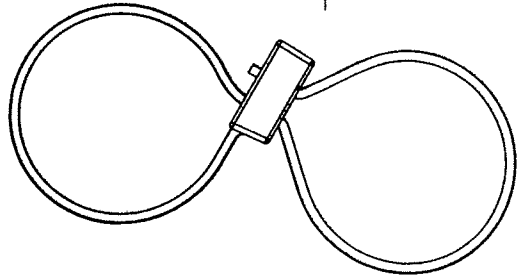
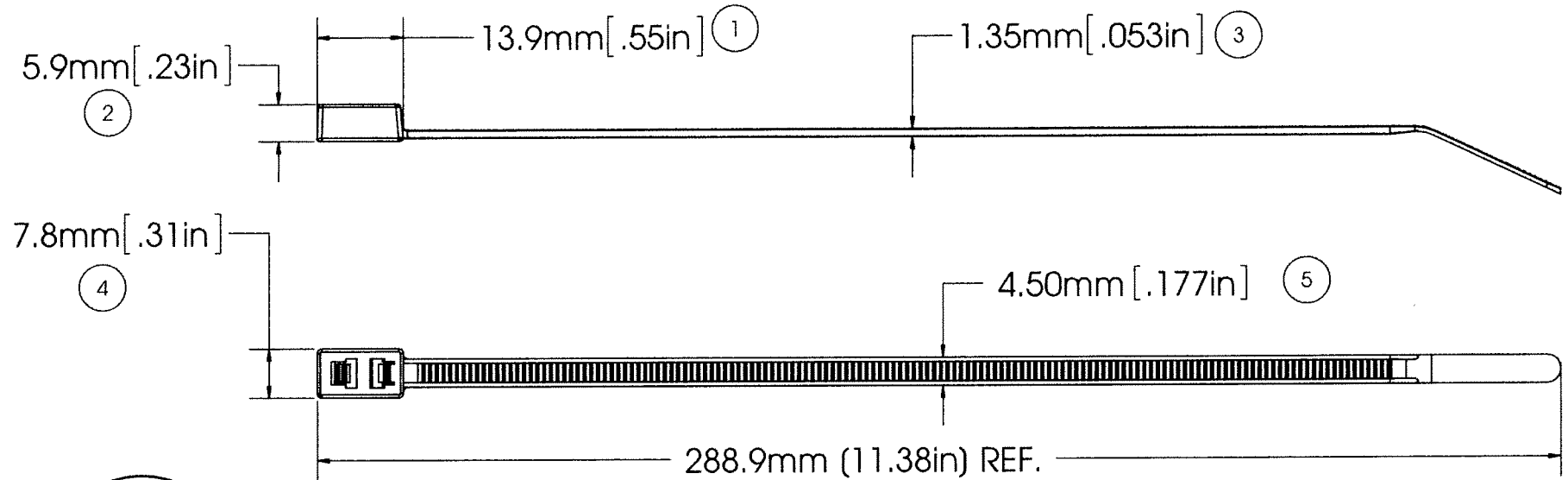

**ASSEMBLED VIEW**

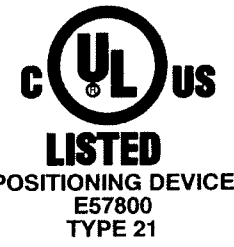

LOOP TENSILE STRENGTH:	50 LBF / 220N MIN. PER AS-23190
OPERATING TEMP RANGE:	-40°F (-40°C) TO 176°F (80°C)
MIN. INSTALLATION TEMP.:	32°F (0°C)
WEIGHT:	0.070 OZ./1.994 GRAMS
BUNDLE DIAMETER:	.063" MIN TO: ONE LOOP UP TO Ø3" OR TWO LOOPS UP TO Ø1.38 EACH
TOOL:	12001 - HAND INSTALLATION TOOL 12500 - PNUEM. INSTALLATION TOOL
TOOL TENSION SETTING:	6 - 8
PACKAGING:	1000/BAG 5000/CASE

NOTE: THESE CABLE TIES ARE UV RESISTANT AND HAVE A FLAMMABILITY RATING OF V-2

APPROVALS: ENG. APPR. *[Signature]* 10/14/14  
Q.A. APPR. *[Signature]* 10/14/14

SPECIFIED TOLERANCES ARE:		MATERIAL
.XX ± .03 IN.	.X ± .7 MM	<b>NYLON 6/6, WEATHER RESISTANT</b>
.XXX ± .01 IN.	.XX ± .25 MM	COLOR
ANGULAR: ± 2°		<b>BLACK</b>

<b>AVERY DENNISON</b> <small>FASTENER DIVISION FITCHBURG, MA 01420 U.S.A. TEL: 1-800-225-5913 FAX: 978-353-6157</small>	DESCRIPTION	<b>11" CABLE TIE, STD, DOUBLE HEADED</b>
	STOCK NO.	<b>10432-0</b>
	REV.	<b>L</b>